

KAWAI

K SERIES
PROFESSIONAL UPRIGHT PIANOS

A GENERATION AHEAD



1980

Introduction of die-cast aluminum action brackets

1984

Exclusive Carbon Jack introduced in grand piano actions

1996

ABS Styran used for full wippen assembly, hammer flange and damper action

2006

Kawai introduces Millennium III Upright Action with ABS-Carbon

AWARD-WINNING QUALITY

KAWAI PIANOS ARE AMONG THE INDUSTRY'S MOST DECORATED KEYBOARD INSTRUMENTS HAVING WON SEVEN "ACOUSTIC PIANO OF THE YEAR" AWARDS FROM 2003 TO 2011*



2011 • 2010 • 2009 • 2008

ACOUSTIC PIANO OF THE YEAR

KAWAI K-3 PROFESSIONAL UPRIGHT PIANO



2005 • 2004 • 2003

ACOUSTIC PIANO LINE OF THE YEAR

KAWAI RX SERIES GRAND PIANOS

*As selected by the readers of *Musical Merchandise Review* magazine.



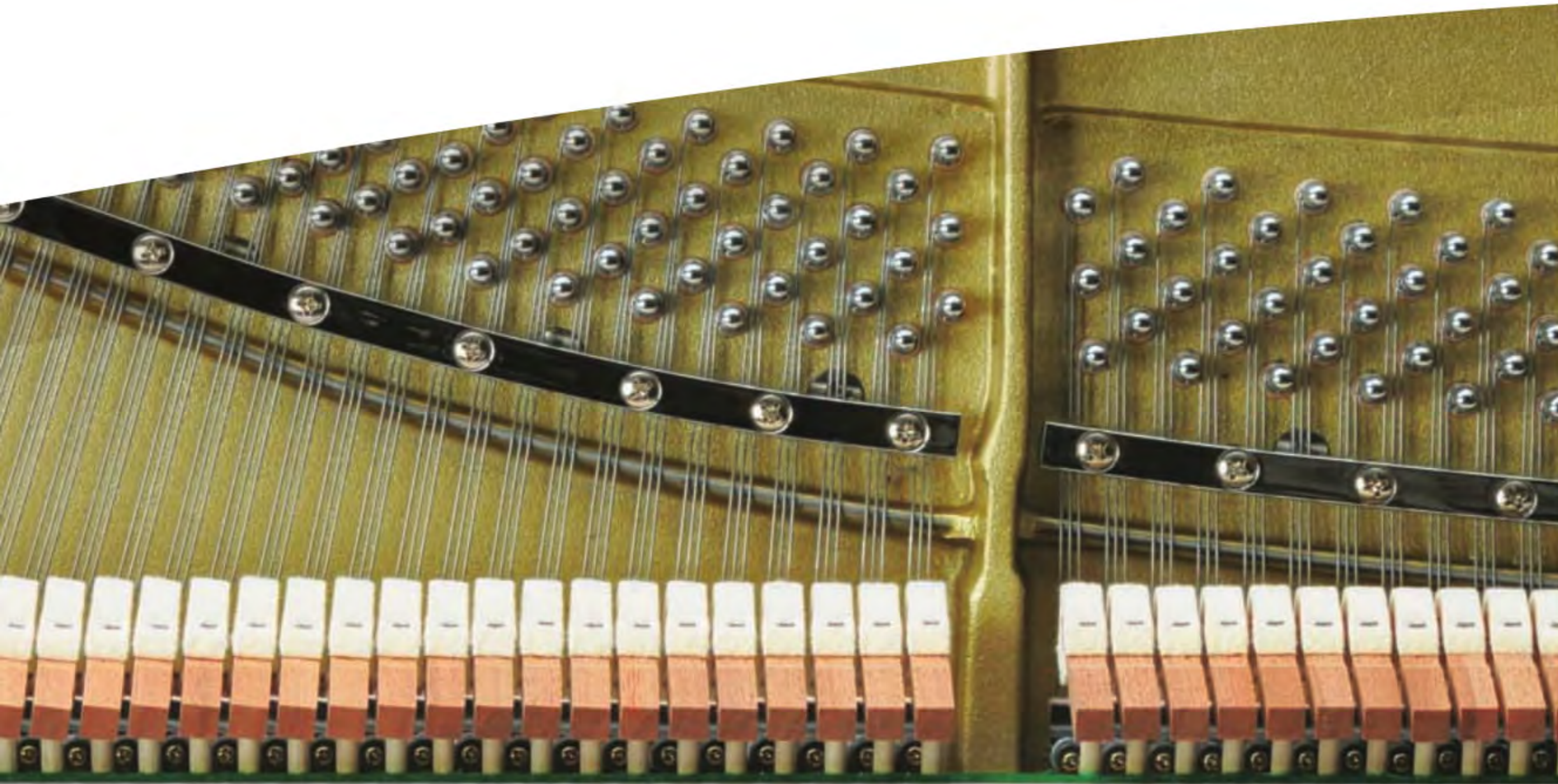

INDUSTRY-LEADING DESIGN

THE REVOLUTIONARY MILLENNIUM III UPRIGHT ACTION IS THE SECRET BEHIND THE ULTRA-RESPONSIVE TOUCH OF THE K SERIES UPRIGHT PIANOS.

Introduced in 2006, the **Millennium III Upright Action** features components made of ABS-Carbon, a composite material created by the infusion of carbon fiber into our renowned ABS Styran. ABS-Carbon is incredibly sturdy and rigid, which allows the creation of action parts that are lighter without sacrificing strength. The result is a stronger, faster action that offers more power, better control and greater stability than conventional all-wood actions.

STRENGTH

ABS-Carbon action parts are lighter in weight but stronger than comparable wooden parts.

SPEED

Lighter weight makes this action approximately 16% faster than comparable wooden actions.

POWER

The rigidity of ABS-Carbon provides more power with less effort.

CONTROL

A slimmer, redesigned jack offers unparalleled control for pianissimo playing.

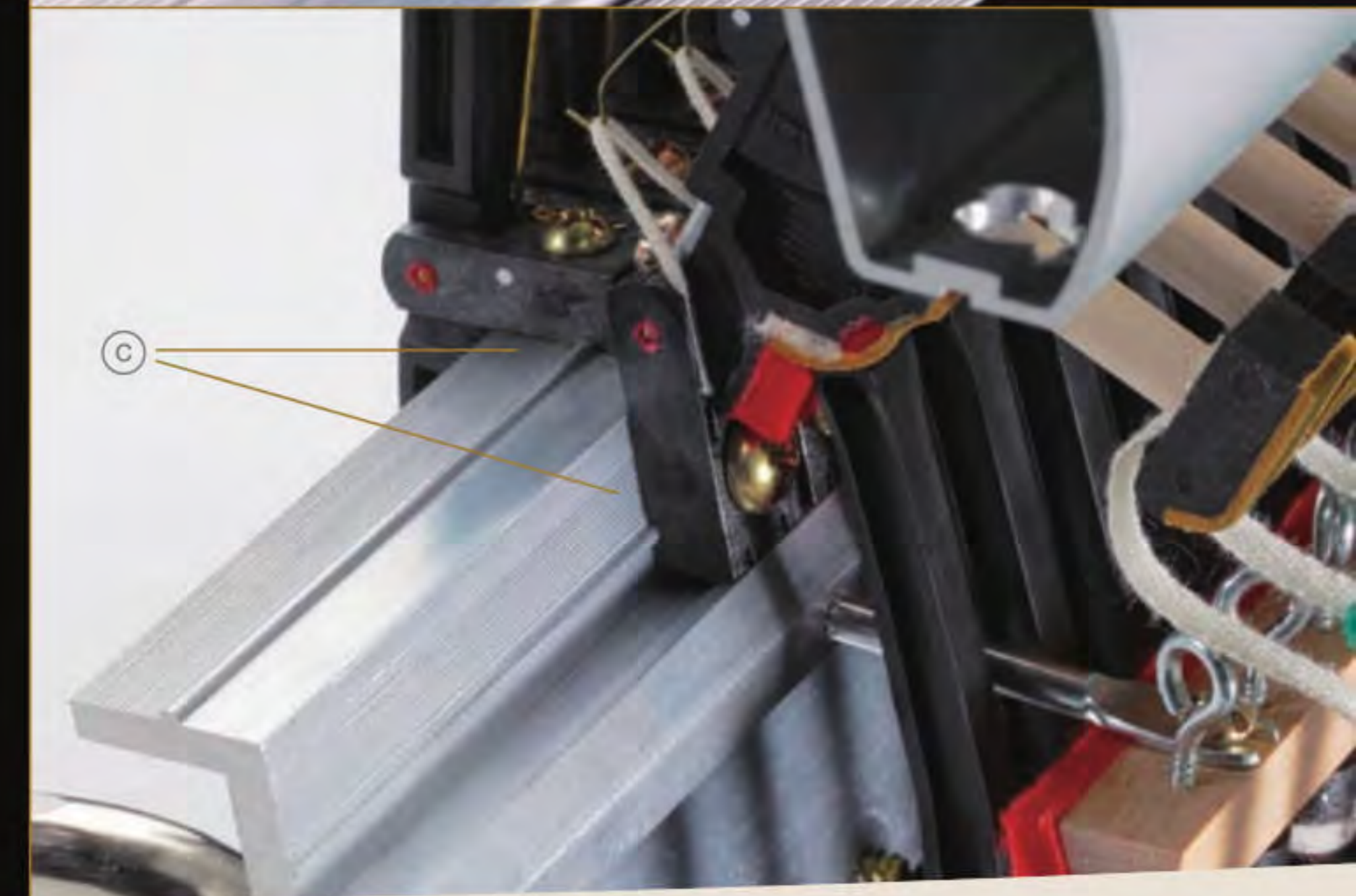
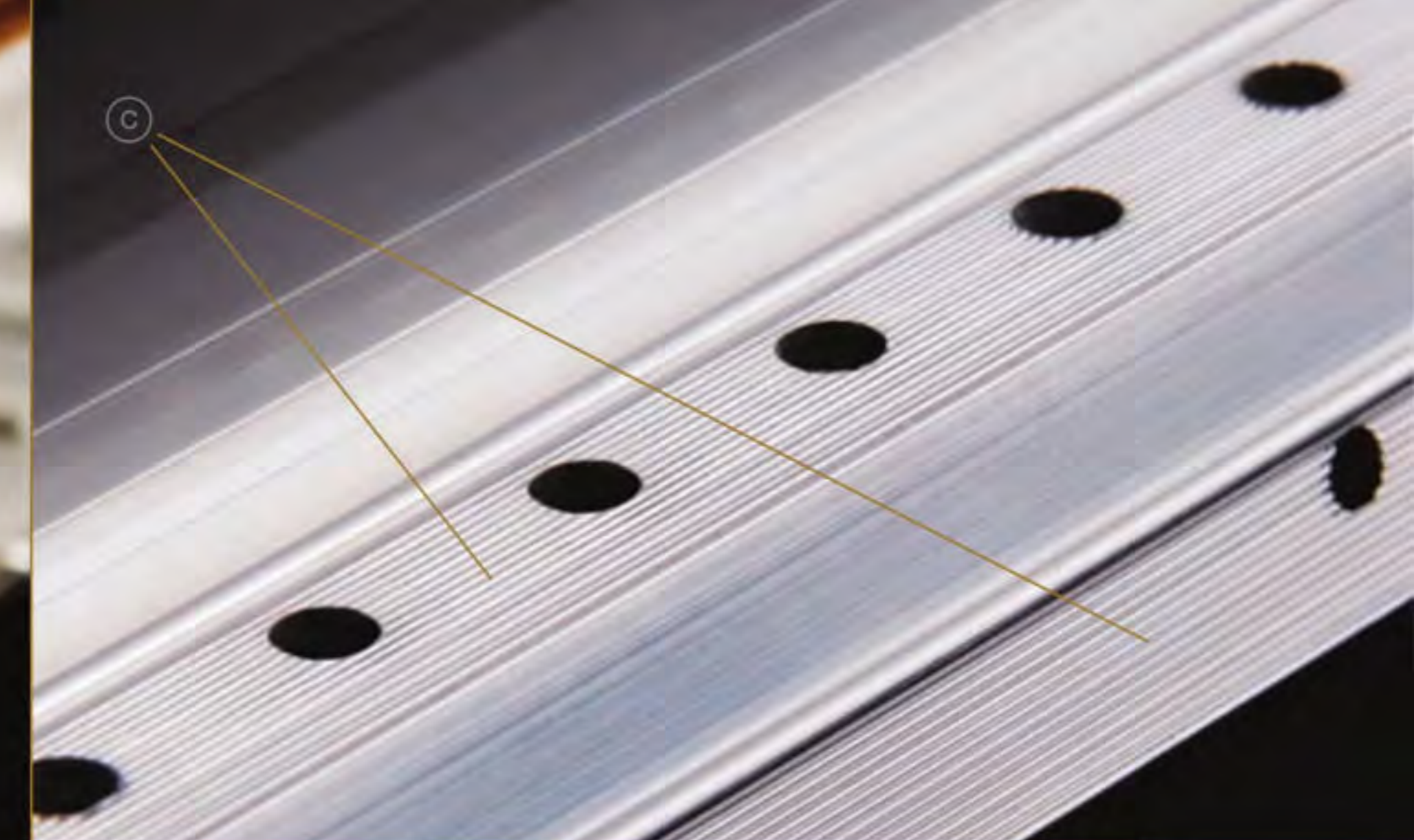

TOUCH

TOUCH IS THE QUINTESSENTIAL KEY TO JOY, INSPIRATION AND ARTISTRY. PRECISE, CONSISTENT TOUCH IS THE HALLMARK OF EVERY KAWAI PIANO.

MAXIMUM PRECISION

- (A) DIE-CAST ALUMINUM ACTION BRACKETS**
Made from a custom mold, die-cast parts are formed exactly the same every time. The K Series pianos feature three aluminum action brackets that are die-cast to provide an added measure of strength, uniformity and stability for accurate touch over time.
- (B) DUAL-BEAM ALUMINUM ACTION RAIL**
The action rail is the “spine” of the piano’s action. K Series action rails are made of durable extruded aluminum with our advanced Dual-Beam design for strength and stability.

- (C) SERRATED RAIL SURFACE**
The action rail surface is finely serrated in three strategic areas to secure the hammer, wippen and damper flanges in place for optimum action alignment and a more precise hammer strike.
- (D) ABS-CARBON ACTION PARTS**
The use of ABS-Carbon makes the action parts tremendously strong and consistent. ABS-Carbon is many times stronger than wood and is virtually impervious to shrinking and swelling due to humidity. This extraordinary combination of strength and stability allows ABS-Carbon action parts to transfer energy to the hammers with unparalleled efficiency, power, precision and nuance for a superb playing experience.

TONE

TRADITION AND TECHNOLOGY ARE INDISPENSABLE ELEMENTS OF PIANO TONE. TRADITION LAYS THE FOUNDATION FOR OUR DISTINCTIVE TONAL CHARACTER. TECHNOLOGY EMPOWERS IT WITH LIFE, BREADTH, AND DEPTH THAT LASTS FROM GENERATION TO GENERATION.





Ⓐ TAPERED SOUNDBOARDS MADE OF SOLID SPRUCE
The soundboard is the heart of a piano. Its purpose is to transform the vibrations of the piano's strings into a rich, resounding tone. Kawai uses only straight-grained, quarter-sawn solid spruce for K Series soundboards. Each soundboard is strategically tapered to maximize its tone producing capability. Only those that meet or exceed our demanding quality standards are selected for use in our professional upright pianos.

Ⓑ FULL-LENGTH RIBS NOTCHED TO THE RIM LINER
The piano's soundboard is placed under tension to create a slight curvature—or crown—that dramatically increases the production of sound. K Series pianos feature full-length ribs that are securely notched into the rim liner on all sides to preserve the soundboard crown over time. The ribs also distribute sound energy more evenly across the soundboard to optimize its tone-producing capabilities.

Ⓒ ENERGY-REFLECTING CONTOUR BARS
Contour Bars reshape the speaking area of the soundboard to resemble the contour of a grand piano soundboard while reflecting sound energy back into the center for increased tonal power and sustain.

Ⓓ T-STAPLED, DOUBLE FELTED HAMMERS
All K Series hammers are T-Stapled to preserve hammer shape and fitted with an added interior layer of underfelt to support the creation of exceptional tone.

Ⓔ BRIDGES
Bridges transfer the vibrations of the strings to the soundboard. K Series bridges are made from select hard maple, individually notched for a clear, powerful tone quality. Height is carefully set and matched to the iron plate for correct string pressure and optimal tonal transfer.

STRENGTH

THE STRENGTH OF A WELL-CRAFTED INSTRUMENT MAKES THE PIANO ONE OF THE MOST IMPRESSIVE EXAMPLES OF TECHNOLOGY, ENGINEERING AND CRAFTSMANSHIP IN THE WORLD TODAY. K SERIES PROFESSIONAL UPRIGHT PIANOS ARE DESIGNED WITH TREMENDOUS STRENGTH TO ENSURE STABILITY OF TONE AND TOUCH OVER TIME.



STRONG, BALANCED BACK ASSEMBLY

On all K Series models, the soundboard is supported by exceptionally strong multi-layered back posts and our proprietary “matched strength” iron plate. Using state-of-the-art CAD technology, we calibrate the strength and mass of the plate to match the scale design of each individual model. This philosophy ensures a sturdy, well-balanced back assembly that supports string tension and provides a solid foundation for outstanding tone.

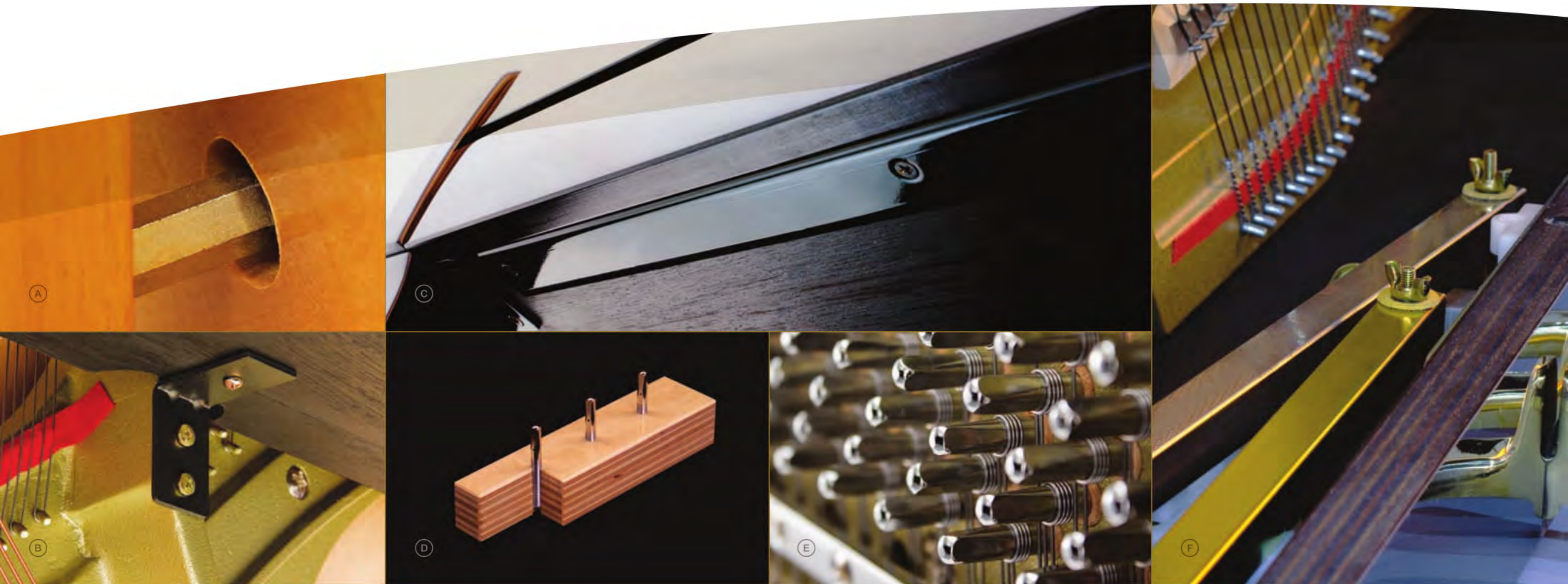

Ⓐ PLATE BOLTS

Plate bolts strengthen the connection between the plate and back posts for greater stability.

Ⓑ KEYBED AND BRACES

The piano's keybed must be strong and stable to support the action assembly and maintain action regulation over years of heavy use. K Series keybeds are made with sturdy laminated hardwoods and reinforced by rear braces on the iron frame that help to ensure stable placement and add rigidity to prevent energy loss.

Ⓒ STEEL-REINFORCED KEYSLIP

A piano's keyslip is the long, horizontal piece of wood that covers the front faces of the keys. Because it is long, thin and made of wood, a keyslip can warp or bend with changes in humidity, causing keys to stick. To eliminate this problem, a heavy-gauge steel angle iron is added to prevent warping or bending in any direction. Keys move freely with virtually no possibility of rubbing or sticking against the keyslip.

Ⓓ MULTI-GRIP PINBLOCK

The Multi-Grip pinblock on all K Series pianos is multi-laminated with a minimum of eleven cross-banded layers of North American hard maple for maximum strength and consistent torque.

Ⓔ TUNING PINS

K Series tuning pins are made from the finest steel, machine-threaded for maximum bi-directional torque and nickel plated to enhance beauty and provide long-term protection.

Ⓕ SQUARE-TUBE PEDAL LEVERS

The square-tube design of K Series pedal levers makes them stronger than the lower cost round-tube levers with flattened ends found on many other pianos. In addition, the square shape provides a flat surface for the wing nuts which helps to prevent unwanted noise and enables a more stable pedal adjustment.



B



C



D



F



E



G

A ATTRACTIVE CABINET STYLING

The K Series pianos feature sleek lines and delicate accents that convey a striking, stately presence. Combining elegant form with rich, vibrant textures of tone, they will surely enhance the cultural ambiance of any room.

B "SOFT FALL" FALLBOARD CLOSING SYSTEM

The ultra-slow "Soft Fall" closing system protects hands and the piano's finish from the harm that a jarring close might cause.

C CAST BRASS PEDALS

Our proprietary casting process binds molten brass to a sturdy steel core resulting in strong, beautiful pedals that will not wear through over time.

D BRASS FRONT CASTERS

Front casters made of solid brass are as sturdy as they are attractive. Double casters are used for the larger K Series models (from K-300 through K-800).

E LONGER MUSIC RACK (K-500, K-300 and K-200)

Conveniently built into the fallboard, the music rack on K-500, K-300 and K-200 extends nearly forty inches to accommodate multiple music books or sheet music that extends laterally.

F HEIGHT ADJUSTABLE BENCH

The height adjustable bench on all K Series models is especially valuable for teaching studios with many students and for families with more than one player.

G TEN YEAR FULL WARRANTY

To ensure your peace of mind and protect the value of your investment, every Kawai upright piano is covered by our Ten Year Fully Transferrable Warranty. This warranty is the seal of Kawai craftsmanship—and the assurance of your satisfaction for many years to come.

K-800

The 53" K-800 is the epitome of upright piano craftsmanship. Its elegant form and exceptional tone will fulfill the needs of any professional teaching studio or intimate performance setting.

- Exclusive Millennium III Upright Action with ABS-Carbon Composites
- Agraffes
Agraffes ensure accuracy in string alignment, spacing and angles to produce greater uniformity, enhanced tone, smoother tuning and consistent "speaking length" for each note.
- Full Duplex Scale (Upper & Lower)
The duplex scale enhances harmonics in the treble range, adding brilliance and richness to the piano's tone.
- Royal George Hammer Felt
- True Sostenuto Pedal
- Grand-Style "Hard Finish" Music Rack (41"L x 13"H)
- NEOTEX™ Key Surfaces
- Double Felted, Mahogany Core Hammers
- Height Adjustable Bench

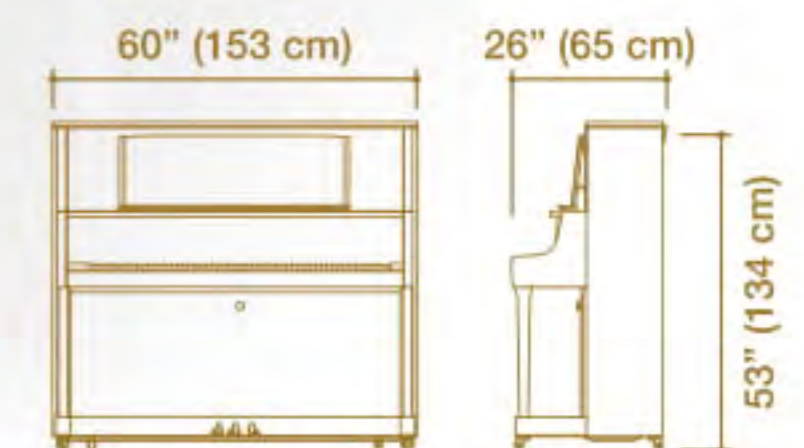

Available Finish:
■ Polished Ebony

Weight: 626 lbs (284 kg)

K-500

With its taller 51" height and newly-designed scale, the K-500 offers a rare combination of power, dynamic range and tonal richness to meet the musical demands of any studio environment.

- Exclusive Millennium III Upright Action with ABS-Carbon Composites
- Duplex Scale (Upper)
The duplex scale enhances harmonics in the treble range, adding brilliance and richness to the piano's tone.
- NEOTEX™ Key Surfaces
- Double Felted, Mahogany Core Hammers
- Height Adjustable Bench

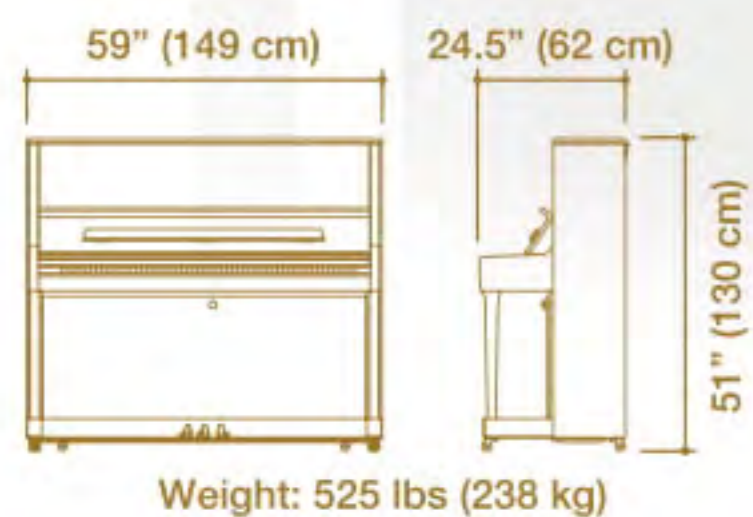

Available Finishes:

- Polished Ebony (above)
- Satin Ebony
- Polished Sapeli Mahogany



Polished Sapeli Mahogany

K-400

The uniquely practical 48" K-400 features a grand-style music rack that places music at eye level and provides a solid surface for sheet music and oversized music books. A New England Style, dual-hinged fallboard adds to its distinctive appeal.

- Exclusive Millennium III Upright Action with ABS-Carbon Composites
- Grand-Style Music Rack (37"L x 10"H)
- New England Style Dual-Hinged Fallboard
- Award-Winning Specifications of the K-300
- Height Adjustable Bench
- Available with Nickel Hardware

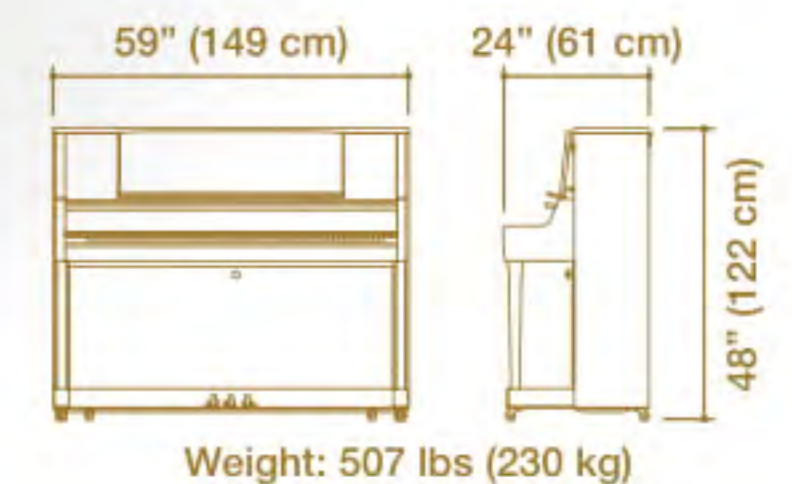

Available Finish:
■ Polished Ebony

Weight: 507 lbs (230 kg)

K-300

The K-300 builds upon the success of its award-winning predecessor, the K-3, that was named Acoustic Piano of the Year in four consecutive years.* The K-300 proudly extends this distinguished legacy.

- Exclusive Millennium III Upright Action with ABS-Carbon Composites
- Popular 48" Height for Home or Studio
- Double Felted, Mahogany Core Hammers
- Height Adjustable Bench
- Available with Nickel Hardware

*by the readers of *MMR Magazine* (2008-2011)



Satin Mahogany



Polished Snow White

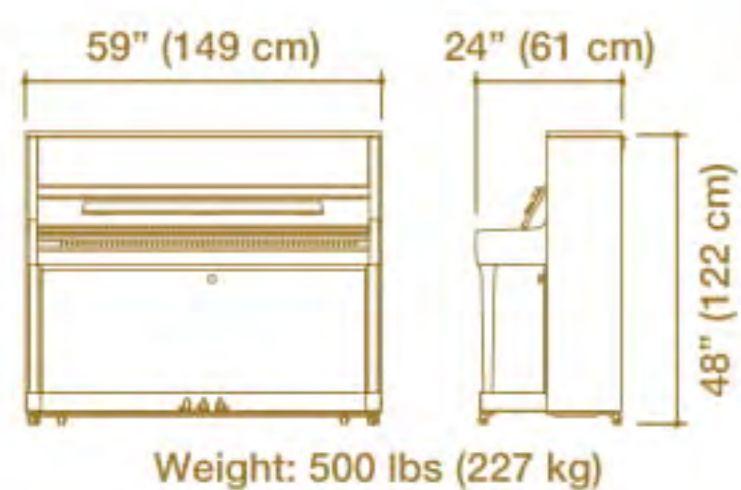

Available Finishes:

- Polished Ebony (above)
- Satin Ebony
- Polished Mahogany
- Satin Mahogany
- Polished Snow White

K-200

With outstanding tone and touch in a 45" frame, the K-200 offers the dependability and character needed to please any performing pianist from the novice to the seasoned professional.

- Exclusive Millennium III Upright Action with ABS-Carbon Composites
- Double Felted, Mahogany Core Hammers
- Height Adjustable Bench
- Available with Nickel Hardware



Polished Ebony with Nickel Hardware

Available Finishes:

- Polished Ebony
- Satin Ebony
- Polished Mahogany (above)
- Satin Mahogany

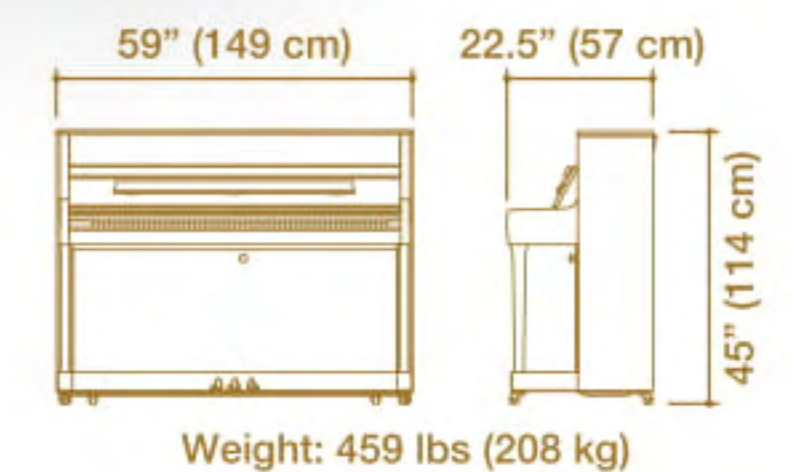

K SERIES SPECIFICATIONS

| | | K-800 | K-500 | K-400 | K-300 | K-200 |
|------------------|--------------|----------------------------------|----------------------------------|----------------------------------|----------------------------------|----------------------------------|
| SIZE | Height | 53" / 134 cm | 51" / 130 cm | 48" / 122 cm | 48" / 122 cm | 45" / 114 cm |
| | Width | 60" / 153 cm | 59" / 149 cm | 59" / 149 cm | 59" / 149 cm | 59" / 149 cm |
| | Depth | 26" / 65 cm | 24.5" / 62 cm | 24" / 61 cm | 24" / 61 cm | 22.5" / 57 cm |
| | Weight | 626 lbs / 284 kg | 525 lbs / 238 kg | 507 lbs / 230 kg | 500 lbs / 227 kg | 459 lbs / 208 kg |
| ACTION | | Millennium III | Millennium III | Millennium III | Millennium III | Millennium III |
| SOUNDBOARD | Size | 2356 sq in / 1.52 m ² | 2248 sq in / 1.45 m ² | 2155 sq in / 1.39 m ² | 2155 sq in / 1.39 m ² | 2077 sq in / 1.34 m ² |
| | Material | Solid Spruce, Tapered | Solid Spruce, Tapered | Solid Spruce, Tapered | Solid Spruce, Tapered | Solid Spruce, Tapered |
| | Ribs | 12 | 11 | 11 | 11 | 10 |
| BACK POSTS | | 6 | 5 | 5 | 5 | 4 |
| CONTOUR BARS | | 2 | 2 | 2 | 2 | 1 |
| #1 STRING LENGTH | | 50.4" / 1280 mm | 48.4" / 1230 mm | 47.2" / 1200 mm | 47.2" / 1200 mm | 45.6" / 1157 mm |
| TUNING PINS | | Nickel Plated | Nickel Plated | Nickel Plated | Nickel Plated | Nickel Plated |
| KEY SURFACES | | NEOTEX™ | NEOTEX™ | Acrylic/Phenol | Acrylic/Phenol | Acrylic/Phenol |
| HAMMERS | Moulding | Mahogany | Mahogany | Mahogany | Mahogany | Mahogany |
| | Felt | Double Felted, Royal George | Double Felted | Double Felted | Double Felted | Double Felted |
| DUPLEX SCALE | | Upper & Lower | Upper | | | |
| AGRAFFES | | • | | | | |
| CENTER PEDAL | | Sostenuto | Practice | Practice | Practice | Practice |
| FRONT CASTERS | | Double, Brass | Double, Brass | Double, Brass | Double, Brass | Single, Brass |
| MUSIC RACK | Style | Grand Style | Fallboard Rack | Grand Style | Fallboard Rack | Fallboard Rack |
| | Length | 41.3" / 105 cm | 39.4" / 100 cm | 37.0" / 94 cm | 39.4" / 100 cm | 39.4" / 100 cm |
| FALLBOARD | Style | Grand Style | Traditional | New England Style | Traditional | Traditional |
| | Closing Type | Soft Fall | Soft Fall | Soft Fall | Soft Fall | Soft Fall |
| LOCK | | • | • | | | |
| BENCH | | Height Adjustable | Height Adjustable | Height Adjustable | Height Adjustable | Height Adjustable |

AVAILABLE FINISHES VARY BY MODEL:



Polished Ebony



Satin Ebony



Polished Mahogany



Satin Mahogany



Polished Sapeli Mahogany



Polished Snow White

Specifications subject to change without notice.

CARING FOR OUR WORLD

IN 1997, KAWAI'S RYUYO GRAND PIANO FACTORY BECAME THE FIRST IN THE PIANO INDUSTRY TO RECEIVE ISO14001, THE WORLD'S MOST PRESTIGIOUS CERTIFICATION FOR EXCELLENCE IN ENVIRONMENTAL MANAGEMENT.



At Ryuyo, work groups continuously monitor and improve emissions and waste control, green procurement, and a host of other energy conservation and environmental protection measures. The Kawai Forest Project has already planted over 350,000 seedlings with a goal to have over 500,000 new trees planted by the end of the decade. These vital efforts will continue to be a part of every piano we build. That is our promise to you—and to our world.

A FAMILY TRADITION

THERE IS NO MORE COMPELLING REASON TO BUILD AN EXCEPTIONAL PIANO THAN HAVING ONE'S OWN NAME ON IT. FOR THREE GENERATIONS, THE KAWAI FAMILY HAS BLENDED KNOWLEDGE, SKILL, TECHNOLOGY AND HEART IN THE QUEST TO PERFECT THE ART OF THE PIANO.



KOICHI KAWAI
(1886-1955)
Founder, Inventor,
Master Builder.



SHIGERU KAWAI
(1922-2006)
Pursued excellence at
Kawai for over fifty years.



HIROTAKA KAWAI
President
Continuing the pursuit
of perfection.



KAWAI
THE FUTURE OF THE PIANO

www.kawaius.com